



Key Features:

- +15 to 40VDC Supply Voltage
- H-Bridge, 2 Phase Bi-polar Micro-stepping Drive
- Suitable for 2-phase, 4, 6 and 8 leads step motors, with Nema size 16 to 23
- Output current selectable from 0.21 ~ 1.5A peak
- Compact credit card size package
- Optically isolated single ended TTL inputs for Pulse, Direction and Enable signal inputs
- Selectable resolutions up to 12800 steps
- Over Voltage, Coil to Coil and Coil to Ground short circuit protection.

Introduction

PSD4015-2P is a bi-polar two-phase micro-stepping drive in a compact credit card size package. It is design for ultimate performance at a very cost efficient operation. It is best suited for two phase small size motor, which requires very little current, to deliver good speed and torque result. The single ended Pulse, Direction and Enable inputs with Opto-coupler pull up, interface perfectly with majority of the PLC output or PLC motion controller, shortening set up time.

With an automatic optimization speed control technique, the PowerStep series drive output is very stable, with almost zero vibration and noise, performing close to a servo system, allowing the motor to operate smoothly. That helps to fulfill a design requirement of low noise, low heat and high performance.

Specifications

Parameters	Min	Typical	Max	Unit
Output Current (Peak)	0.21	-	1.5	Amps
Supply voltage	15	36	40	VDC
Logic Input Current	7	10	16	mA
Pulse input frequency	0	-	200	KHz
Low Level Time	2.5			μsec

Cooling	Natural Cooling or Forced Convection	
Environment	Space	Avoid dust, oil frost and corrosive gases
	Ambient Temperature	0°C – 50°C
	Humidity	40 – 80%RH
	Vibration	5.9m/s ² Max
Storage Temp.	-10°C – 80°C	
Weight	Approx. 150 gram	

Mechanical Dimensions (mm)

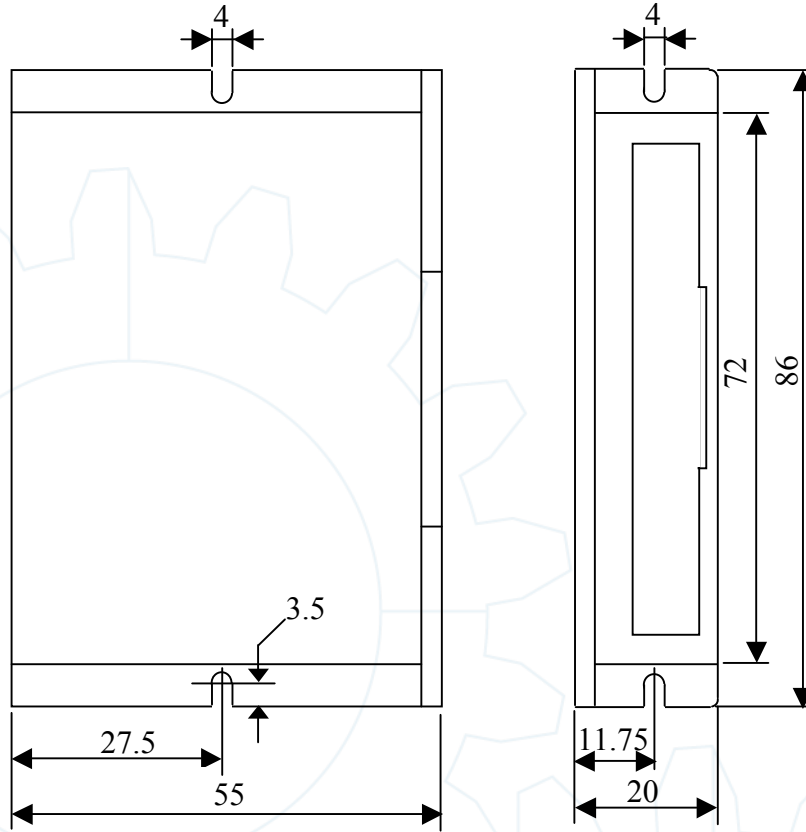

Current Setting

Current Setting (A)	SW1	SW2	SW3
0.21	OFF	ON	ON
0.42	ON	OFF	ON
0.63	OFF	OFF	ON
0.84	ON	ON	OFF
1.05	OFF	ON	OFF
1.26	ON	OFF	OFF
1.50	OFF	OFF	OFF

Microstep Setting

Step / Rev	SW4	SW5	SW6
200	ON	ON	ON
400	OFF	ON	ON
800	ON	OFF	ON
1600	OFF	OFF	ON
3200	ON	ON	OFF
6400	OFF	ON	OFF
12800	ON	OFF	OFF

P1 Terminal Assignment

Signal	Function and Descriptions
PUL	<u>Pulse or Step Input</u> TTL single ended input with high-going pulse, 1.5 μ s min width. For +12V or +24V operation, a current limiting resistor had to be pull up or connected in series between the PUL input and the controller pulse output
DIR	<u>Direction Input</u> Logic High = positive (CW) rotation—4.0 ~ 5.0V Logic Low = negative (CCW) rotation—0 ~ 0.5V The DIR signal must be stable for at least 5ms before the drive receives the first pulse.
ENA	<u>Enable Input</u> Logic High = Drive Enabled Logic Low = Drive Disabled This input, if left unconnected, is recognised as Logic High by the drive, and it will be enabled.
OPTO	Opto-Coupler pull-up voltage for PUL, DIR and ENA signals. Typical voltage is +5VDC.

P2 Terminal Assignment

P2 Signal	Function and Descriptions
GND	DC Power Ground
+V	DC Power Supply, +15VDC ~ +40VDC
A+, A-	<p>4 Leads Motor Full Coil Half Coil</p>
B+, B-	<p>Series Parallel</p> <p>8 Leads Motor</p>

Wiring

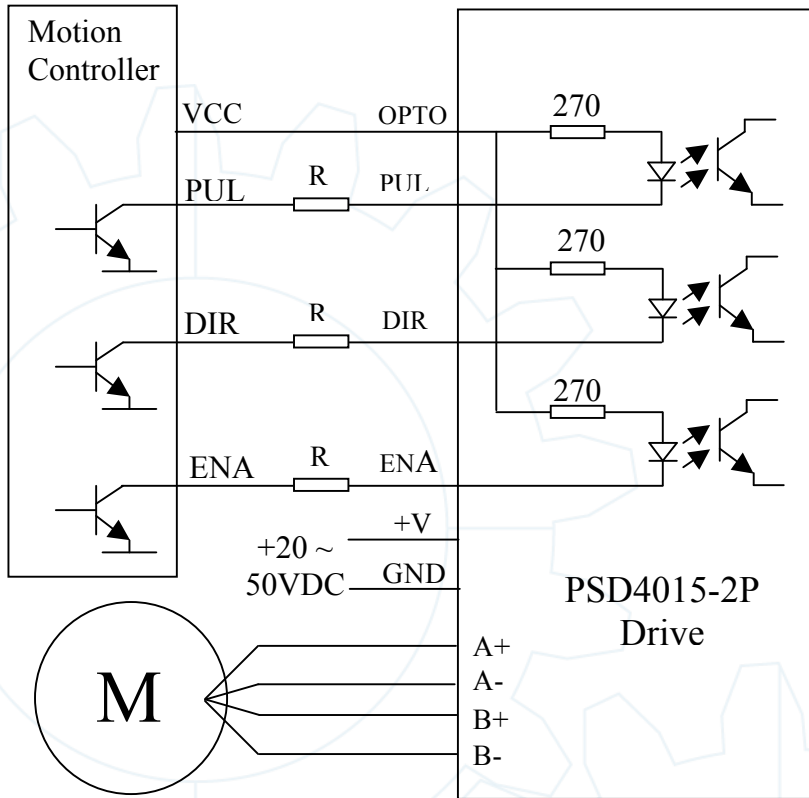

R=0 if VCC=5V
 R=1K(Power>0.125W) if VCC=12V;
 R=2K(Power>0.125W) if VCC=24V;
 R must be connected to control signal terminal.