

Nema 34 Size - 3 Phase Hybrid Step Motor



- Features**
- Low Motor Temperature
 - High Torque
 - Low Vibration
 - Better Acceleration Performance
 - Better Precision

- General Specifications**
- Step Angle : 1.2°
 - Insulation Class : B
 - No of Motor Leads : 6

Mechanical Dimensions (mm)

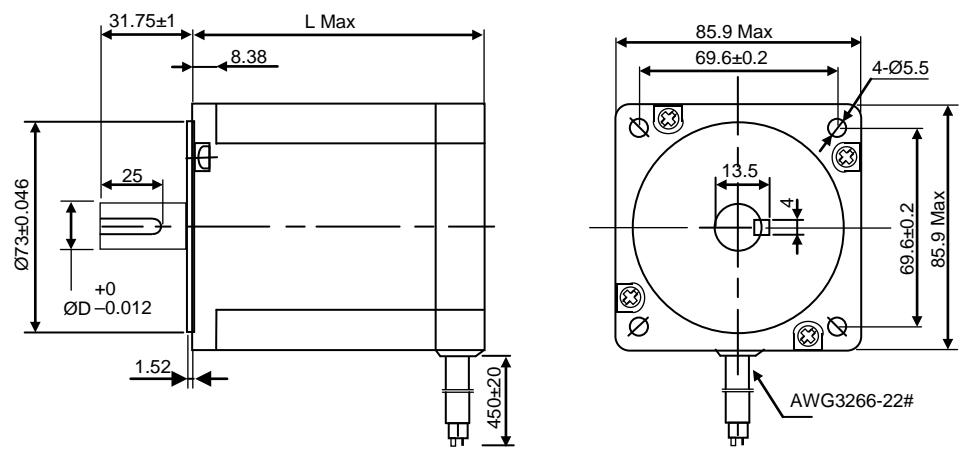

Wiring Diagram

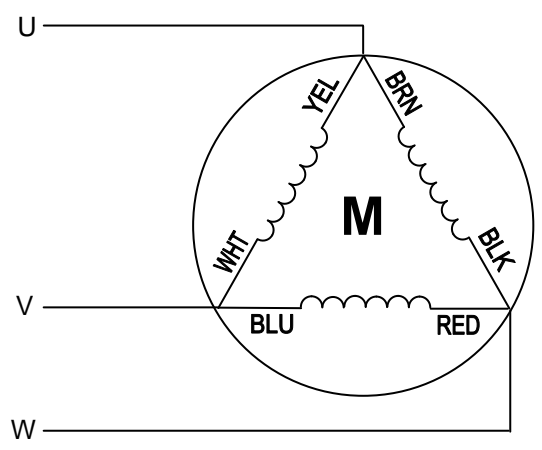

Electrical Specifications

Model	Holding Torque (kgcm)	Current/Phase (A)	Resistance/Phase (Ω)	Inductance/Phase (mh)	Detent Torque (gcm)	Rotor inertia (g-cm ²)	Weight (kg)	Length Lmax (mm)	Shaft ØD (mm)	Keyway (mm)
PSM86J1270-3P	22	5.0	0.96	2.4	1000	1100	1.7	70	12	1 x 25 (Flat Cutout)
PSM86J12103-3P	4.5	2.0	6.5	28	2000	2340	2.85	103	12	4 x 20
PSM86J12135-3P	6.78	2.3	7.7	31	3000	3500	4.0	135	12	4 x 20