

# TKF TYPE

## 주요용도(Application)

덕트형으로 이물질로부터 Cable, Hose 등의 보호를 필요로 하는 공작기계, 산업용로봇 등에 적합한 제품입니다.  
Application for CNC machines used in machining center, industrial robot and so forth.

## 특징(Features)

- 운동속도 : 90M/min 이하 사용가능
- TKF Type Cableveyor는 2.5m 이상은 사용 하지 말 것
- 재질 : Stainless Steel + 엔지니어링 플라스틱
- Stroke - application under 90m/min
- Don't using over 2.5m
- Material : Stainless steel + Engineering plastic
- Best protection from dust and residual substances
- Engineering plastic is used in inside structure to provide insulation.

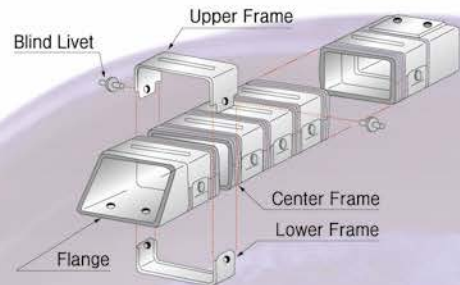
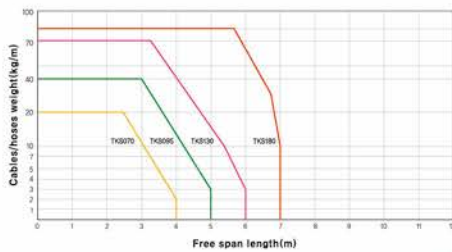

# TKF TYPE

## TKF 055 TYPE

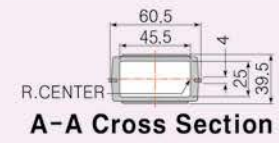
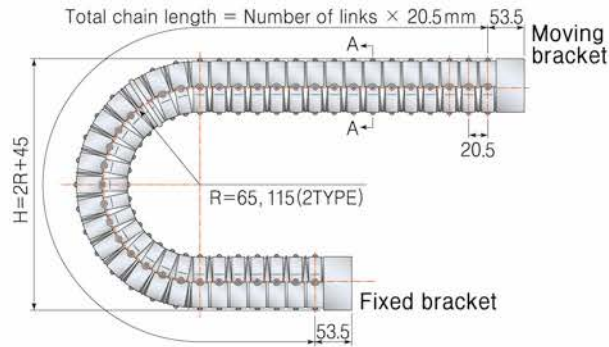

## TKF 085 TYPE

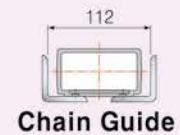
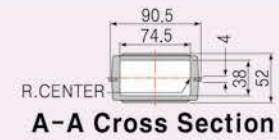
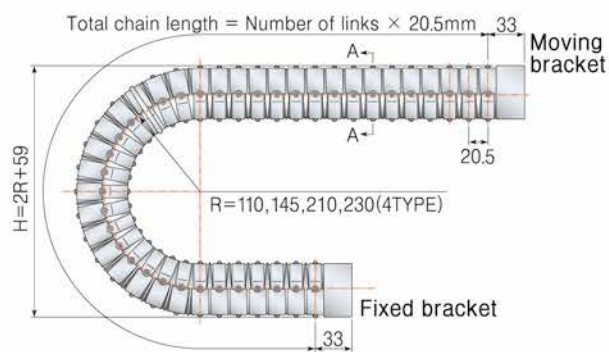

## TKF 115 TYPE

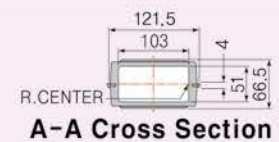
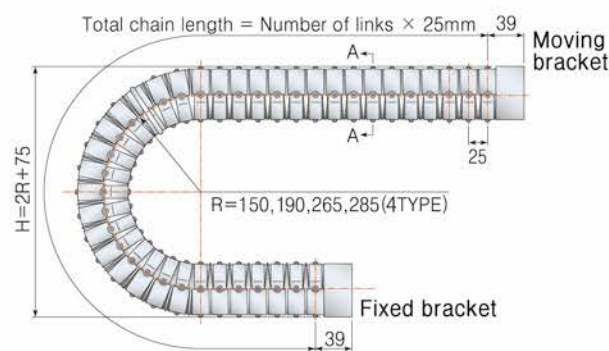

## TKF 175 TYPE

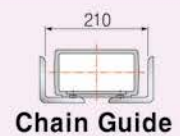
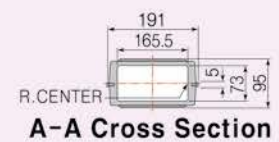
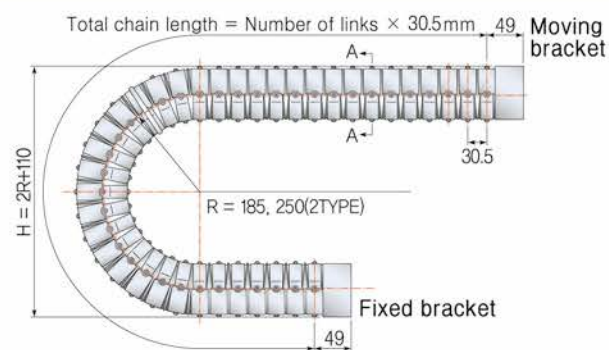

$$\text{Chain Length } L = \frac{Ls}{2} + \pi R + 7A(7L/K)$$

# TKF TYPE 고정브라켓 및 연결 방법

Order Example [ 주문예 ] (B쪽 주문 제작 가능)

TKF 085 / Type ▶ R/곡률반경(Radius) ▶ L / 길이값(링크가능) ▶ SET/ 세트수

## TKF 고정브라켓

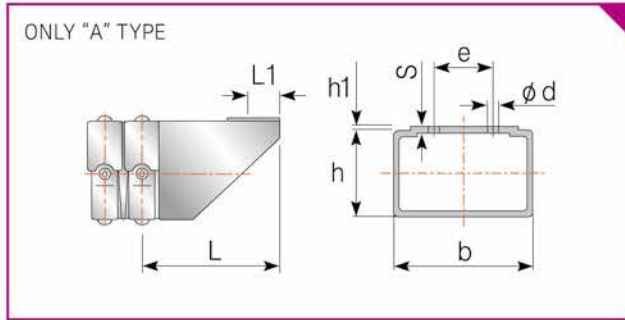

Chain Size	b	h	h <sub>1</sub>	d	e	L	L <sub>1</sub>	S
TKF 055	57	37	2	7	22	53.5	12.5	5.0
TKF 085	87	50	2.0	7	35	73.5	17	5.0
TKF 115	116	64	2.0	9	49	95.5	25	5.0
TKF 175	181	90	4	10	100	104	25	9.0

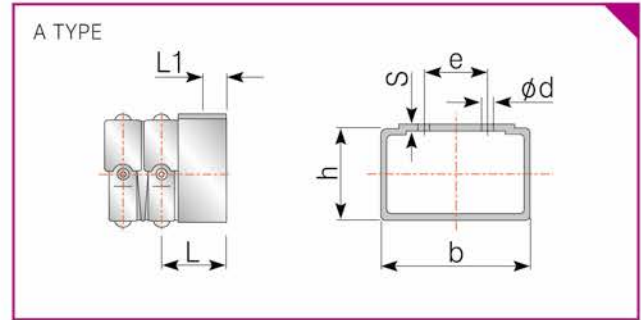

Chain Size	b	h	d	e	L	L <sub>1</sub>	S
TKF 055	57	37	7	22	29.5	8.5	6.5
TKF 085	82.5	48.5	7	50	34.5	10	5.5
TKF 115	116	64	9	65	45.5	10	6.0

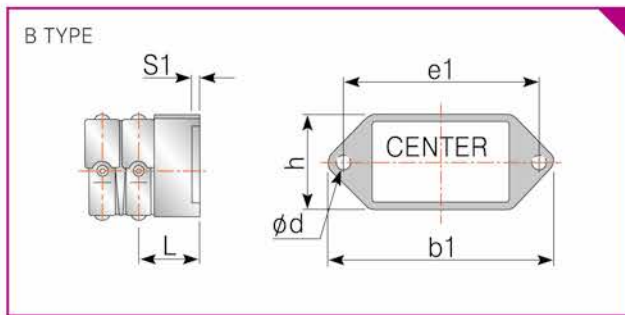

Chain Size	b <sub>1</sub>	h	d	e <sub>1</sub>	L	S <sub>1</sub>
TKF 055	90	40	7	75	29.5	5.0
TKF 085	122	52	7	107	34.5	6.0
TKF 115	165	68	9	146	45.5	6.0

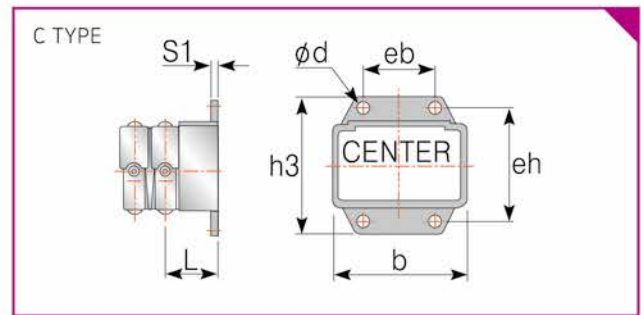

Chain Size	b	h <sub>3</sub>	d	eb	eh	L	S
TKF 055	57	70	7	18	55	29.5	5.0
TKF 085	86	85	7	45	70	34.5	6.0
TKF 115	116	110	9	60	90	45.5	5.5
TKF 175	185.5	138	10	95	110	54	9.0

## 고정브라켓 연결방법 (주문시 고정형태를 기록해 주세요)

TYPE 1  
only A  
(A)

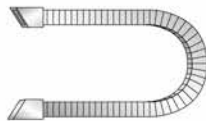

TYPE 2  
only A  
(A)

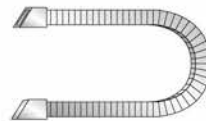

TYPE 3  
only A+B/C  
(A)



TYPE 4  
only A  
(A)

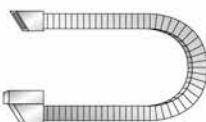

TYPE 5  
only A  
(A)

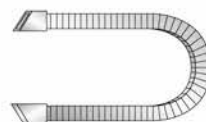

TYPE 6  
only A+B/C  
(A)



TYPE 7  
only A+B/C  
(A)

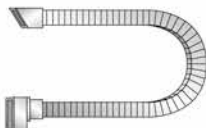

TYPE 8  
only A+B/C  
(A)

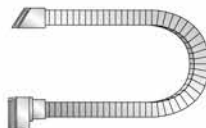

TYPE 9  
B/B, C/C, B/C

